

NOTES:
 All dimensions in metres.
 Do not scale from drawing.
 For any discrepancies found please consult with design office.
 This drawing should be read in conjunction with all contract drawings, documents and specifications.

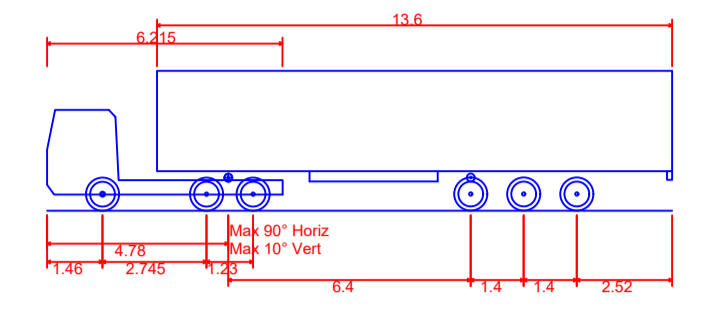

Articulated Vehicle with Twin Steered Tractor
 Overall Length 16.500m
 Overall Width 2.550m
 Overall Body Height 3.691m
 Min Body Ground Clearance 0.426m
 Max Track Width 2.500m
 Lock-to-lock time 6.00s
 Curb to Curb Turning Radius 6.987m

Key Plan

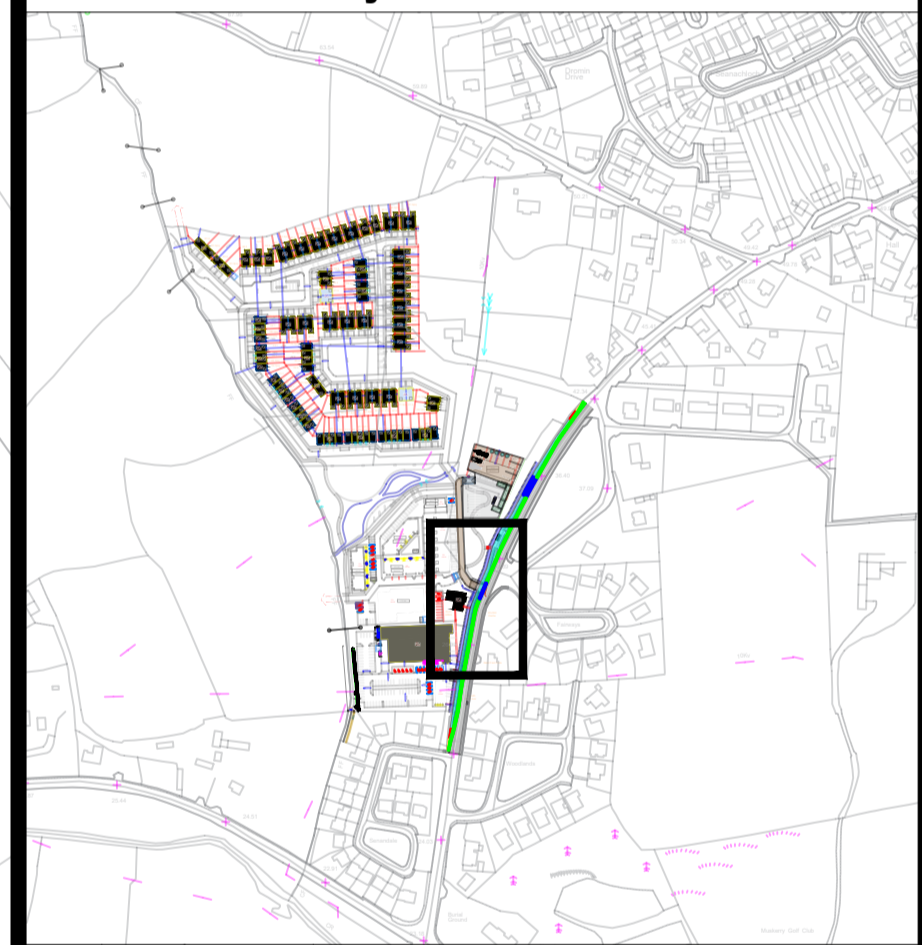

Rev By	Date	Description

Drawing Status: PLANNING
 NOT CERTIFIED FOR CONSTRUCTION

Project Title: Cloghroe Development

Drawing Title: Swept Path Analysis
 Traffic Management Plan
 Sheet 1 of 1

Client: Cloghroe Development Limited

M.H.L. & Associates Ltd.
Consulting Engineers
 Carrig Mór House,
 10 High Street,
 Douglas Road,
 Cork
 Tel: 021-4840214
 Fax: 021-4840215
 E-Mail: info@mhl.ie

Designed: SM	Drawn: SFM	Checked: KM
Scale: 1:200 @ A1	Date: Sept 2021	
Job No: 19083HD	Drawing No: RL1-SPA-P01	Revision: 00